



TRIBUTE HYBRID

EMERGENCY RESPONSE GUIDE





TRIBUTE HYBRID EMERGENCY RESPONSE GUIDE

CONTENTS

FOREWORD.....	- 2 -
TRIBUTE HYBRID VEHICLE IDENTIFICATION	- 3 -
HIGH-VOLTAGE ELECTRICAL AND FUEL DISCONNECT FEATURES.....	- 5 -
HYBRID COMPONENT LOCATION AND IDENTIFICATION	- 6 -
HYBRID COMPONENT LOCATION.....	- 7 -
HIGH-VOLTAGE BATTERY PACK	- 8 -
APPROACHING A DAMAGED HIGH-VOLTAGE VEHICLE.....	- 10 -
NOTES.....	- 12 -



TRIBUTE HYBRID EMERGENCY RESPONSE GUIDE

FOREWORD

The emergency response procedure for the Tribute Hybrid vehicle is similar to those for traditional gasoline-powered vehicles with the addition of special considerations for the high-voltage electric system components.

The Tribute Hybrid vehicle uses a conventional gasoline engine in addition to an electric motor to power the vehicle. The energy used to power the vehicle comes from gasoline (used by the internal combustion engine) and electricity (used by the electric motor).

- Gasoline is stored in a traditional fuel tank.
- Electricity is stored in a high-voltage battery pack.

The combination of a gasoline engine and electric motor provides for improved performance (V6 performance with a 4-cylinder engine and electric motor), reduced emissions and improved fuel economy. The high-voltage system is self contained, never needing to be plugged into an electrical outlet for recharging. The system incorporates a generator that recharges the batteries during cruising and braking. For further information, the following website may be useful:
<http://www.fordvehicles.com/escapehybrid/technology/>.

The information in this guide will allow response to emergencies involving Tribute Hybrid vehicles to be as safe as with conventional vehicles.

The Tribute Hybrid vehicle has been designed with many safety features for your protection. These features help provide safe access to the vehicle under various conditions. However, whenever approaching a high-voltage vehicle in a fire, rescue or recovery situation, always follow one industry standard rule:

***ALWAYS ASSUME THE VEHICLE HIGH-VOLTAGE
SYSTEM IS POWERED UP!!!***



TRIBUTE HYBRID EMERGENCY RESPONSE GUIDE

TRIBUTE HYBRID VEHICLE IDENTIFICATION

- The Tribute Hybrid vehicle can be easily identified by the Mazda “green leaf globe” badges located on the left and right fenders. There is also a “Hybrid” nameplate on the tailgate that also includes the “green leaf” icon.



- The Tribute Hybrid vehicles have a unique left rear quarter glass that incorporates the high-voltage traction battery air intake.



**Green Leaf Globe
Badge on Fenders**

**Unique Left Rear
Quarter Glass
with Traction
Battery Air Intake**

**Hybrid Nameplate
with Green Leaf
Globe Badge on
Tailgate**



TRIBUTE HYBRID EMERGENCY RESPONSE GUIDE

- The Tribute Hybrid vehicle has a unique engine appearance cover with Mazda “Winged M” logo and HYBRID lettering.

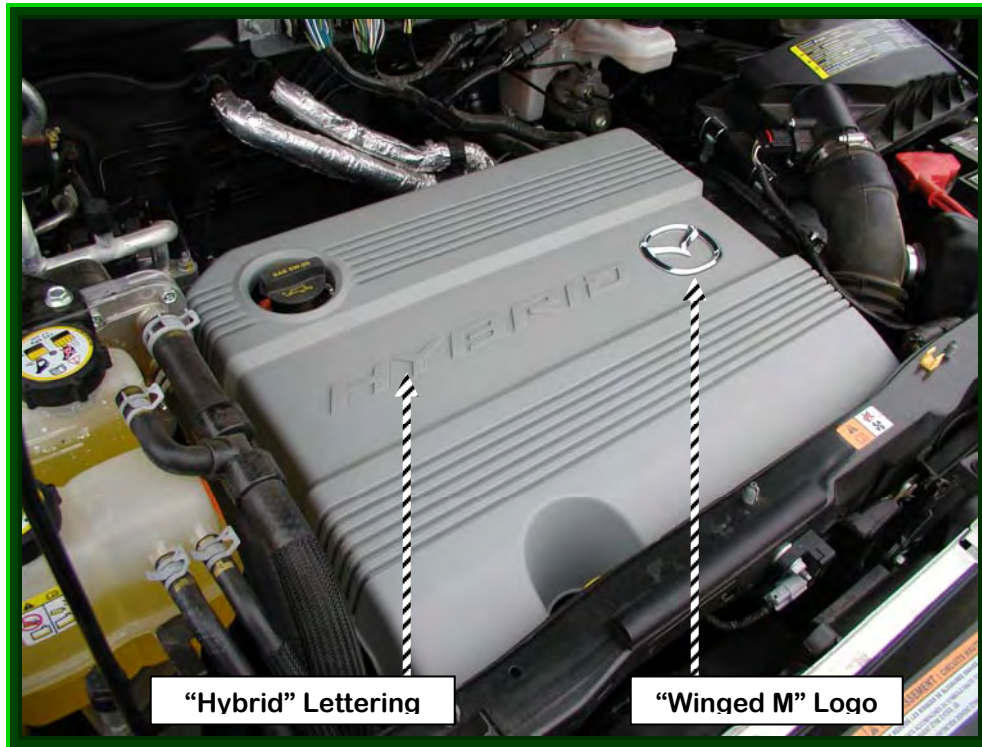

- The 5th, 6th and 7th digits of the vehicle identification number (VIN) identify the hybrid vehicle line.

VIN POSITIONS 5, 6 & 7	VEHICLE
Z49	Tribute Hybrid — Front Wheel Drive (FWD)
Z59	Tribute Hybrid — All Wheel Drive (AWD)

SAMPLE VIN:

4 F 2 C **Z 4 9** H 3 8 K M 0 0 0 0 1



Tribute Hybrid FWD



TRIBUTE HYBRID EMERGENCY RESPONSE GUIDE

HIGH-VOLTAGE ELECTRICAL AND FUEL DISCONNECT FEATURES

The following list describes certain features that have been incorporated into the Hybrid vehicles that allow for either simple or automatic shutoff of the high-voltage electrical and fuel systems.

- Inertia Switch – Fuel Pump Shut-Off — The fuel pump shut-off inertia switch is normally closed to allow vehicle operation. In the event of a collision or a substantial physical jolt, the switch is designed to open automatically shutting off electrical power to the fuel pump and the HV shut-off switch.
- Inertia Switch – High-Voltage (HV) Shut-Off — The HV shut-off switch is located behind the jack access panel in the cargo area on the passenger side of the vehicle. In the event of a collision or a substantial physical jolt, the switch is designed to open automatically disabling the HV system.
- High-Voltage (HV) Fuse — In the event of a high current short circuit, the HV fuse will open disabling the HV system.
- High-Voltage (HV) Interlock Circuit — Whenever a high-voltage connector is disconnected, the HV interlock circuit opens and disables the HV system.
- Ignition Key in OFF Position — Anytime the ignition lock cylinder is in the OFF position, the HV system is disabled.
- High-Voltage Service Disconnect Switch — Whenever the high-voltage service disconnect switch (located on top of the high-voltage battery in the cargo area) is removed, the HV system is disabled. For additional information, refer to Page 9 in this manual.
- Thermal Sensors — In the event the ignition key is left in the ON position, while the vehicle is parked and the HV battery temperature exceeds 60°C (140°F), thermal sensors located near the HV battery will automatically disconnect the HV battery.



TRIBUTE HYBRID EMERGENCY RESPONSE GUIDE

HYBRID COMPONENT LOCATION AND IDENTIFICATION

This chart provides the location, description and basic function of the hybrid system components. Refer to the component location illustration on the following page.

	COMPONENT	LOCATION / DESCRIPTION	FUNCTION
1	High-Voltage Shut-Off Switch	<ul style="list-style-type: none"> Located in the jack stowage compartment, passenger side in the cargo area. 	Disconnects HV battery in the event of a collision
2	High-Voltage Service Disconnect Switch	<ul style="list-style-type: none"> Located on top of the HV battery, passenger side in the cargo area under carpet. Orange in color with molded plastic handle, about 100 mm (4 inch) in diameter. 	Provides means to disconnect HV battery for safely servicing vehicle.
3	High-Voltage Battery — 300+ Volts	<ul style="list-style-type: none"> Located in the cargo area under carpet. Sealed nickel-metal hydride. 	Provides high-voltage storage (300+ V) for vehicle propulsion requirements.
4	High-Voltage Wiring	<ul style="list-style-type: none"> Runs along underside of vehicles cab floor from HV battery to electronically controlled continuously variable transaxle (eCVT) then to DC-to-DC converter. All high-voltage wiring has orange-colored insulation. 	Provides physical path for high-voltage circuitry.
5	12-Volt Battery	<ul style="list-style-type: none"> Located under the hood on driver side of the vehicle. Typical automotive 6-cell lead/acid design. 	Provides 12-volt power for vehicle accessories.
6	Electronically Controlled Continuously Variable Transaxle (eCVT)	<ul style="list-style-type: none"> Transverse-mounted design similar to the non-hybrid Tribute vehicles. Contains the traction motor, generator motor and hybrid electronics. 	Provides delivery of power to wheels for vehicle propulsion, generates electricity to recharge the batteries during braking and coasting, and contains certain hybrid electronics.
7	DC/DC Converter	<ul style="list-style-type: none"> Located under the hood on the passenger side forward of the strut tower. 	Provides 12 volts of power to charge the 12-volt battery and run vehicle accessories.
8	Fuel Shut-Off Inertia Switch	<ul style="list-style-type: none"> Located behind the flip-up panel in the passenger front foot well. 	Disables power supply to the gasoline fuel pump and the HV shut-off switch in the event of a collision.

NOTE: All High-voltage wires and harnesses are wrapped in orange-colored insulation.



TRIBUTE HYBRID EMERGENCY RESPONSE GUIDE

HYBRID COMPONENT LOCATION

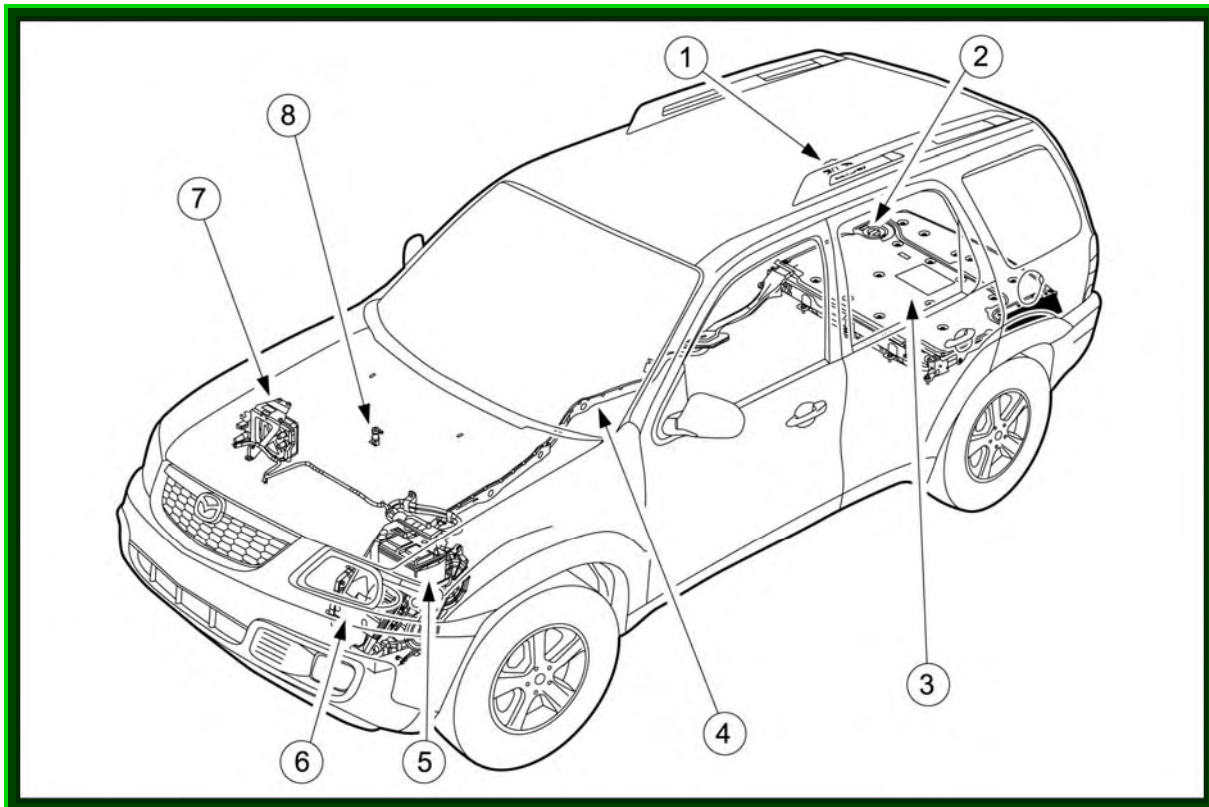

- Warning decals, as shown here, will be located on components included in the high-voltage system.



⚠ WARNING: HIGH VOLTAGE VEHICLE ⚠	
TO REDUCE THE RISK OF POSSIBLE SERIOUS INJURY (SHOCK OR BURN) OR DEATH: COMPONENTS MARKED WITH THE HIGH VOLTAGE SYMBOL ⚠ CONTAIN HIGH VOLTAGE AND HIGH TEMPERATURES AND SHOULD BE AVOIDED. SERVICE MUST BE PERFORMED BY QUALIFIED PERSONNEL ONLY. 📖	
⚠ AVERTISSEMENT : CIRCUITS HAUTE TENSION DU VÉHICULE ⚠	
POUR RÉDUIRE LES RISQUES DE BLESSURES GRAVES (CHOCs OU BRÛLURES) OU MORTELLES : LES ÉLÉMENTS ACCOMPAGNÉS DU SYMBOLE HAUTE TENSION ⚠ ONT UNE TENSION ET DES TEMPÉRATURES ÉLEVÉES ET DOIVENT ÊTRE ÉVITÉS. 📖	
LA RÉPARATION ET L'ENTRETIEN DOIVENT ÊTRE EFFECTUÉS PAR UN TECHNICIEN QUALIFIÉ SEULEMENT.	
4LMA-19B1E-AB	



TRIBUTE HYBRID EMERGENCY RESPONSE GUIDE

HIGH-VOLTAGE BATTERY PACK

The high-voltage battery pack is located in the rear of the vehicle underneath the carpet.

- The high-voltage battery pack consists of 50 battery modules.
- Each module is comprised of 5 nickel-metal hydride (Ni-MH), 1.3-volt batteries welded together.
- Each battery within the module is similar in size and shape to a size D flashlight battery and is sealed in a stainless steel case.
- The total voltage of the battery pack is approximately 300 volts DC.
- The battery case is designed to be water resistant.
- The battery cells contain a base electrolyte (consisting of potassium hydroxide as the dominant active ingredient) that is absorbed in a special paper. The electrolyte will not leak from the battery under most conditions, however, if the battery is crushed, it is possible for a small amount (drops) of electrolyte to leak.

These warnings must be observed when working with a damaged battery:

1. Exposure to electrolyte could cause skin/eye irritation and or burns. If exposed, rinse with large amounts of water until the soapy feel is gone. Personal protective equipment (PPE) such as splash shield or safety goggles, gloves (latex, rubber or Nitrile), an apron or overcoat suitable to protect against alkaline and rubber boots are required when handling damaged batteries. **Fold-down helmet shields are not acceptable for acid or alkaline spills.**
2. If the battery is exposed to intense heat, it is possible that hydrogen could be released from the battery. Appropriate precautions should be taken to make sure the area is properly ventilated, such as, opening the lift gate and vehicle doors and opening or removing the rear glass.

Note: The high-voltage service disconnect switch should be moved to the service/shipping position if possible.



TRIBUTE HYBRID EMERGENCY RESPONSE GUIDE

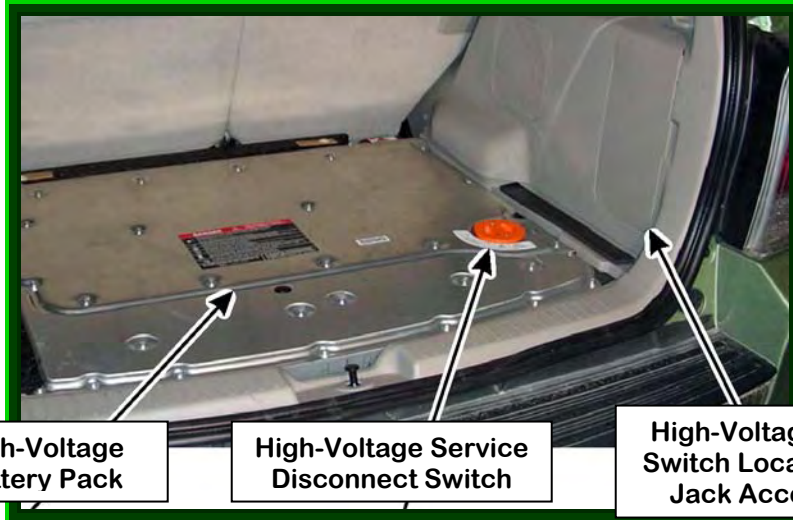

WARNING

- Removing the high-voltage service disconnect switch disconnects high voltage from the vehicle.
- The individual cells inside the battery pack will still be charged.
- Do not cut into the high-voltage battery case or penetrate the batteries in any way.



**High-Voltage Service Disconnect Switch Shown in LOCK position.
High-voltage system is STILL ACTIVE.**

**Remove switch and place in SERVICE/SHIPPING position
to disconnect high-voltage system.**



TRIBUTE HYBRID EMERGENCY RESPONSE GUIDE

APPROACHING A DAMAGED HIGH-VOLTAGE VEHICLE

1. FOLLOW EXISTING TRAINING AND INCIDENT COMMANDER DIRECTION

- This guide provides only supplemental information as it pertains to the Tribute Hybrid vehicle. The same rules apply when approaching any potential high-voltage situation. Always follow your high-voltage safety training. Some precautions to be taken in any high-voltage situation include:
 - Remove all jewelry, watches, necklaces, earrings; etc. Metal objects are conductors of electricity.
 - Wear the necessary PPEs (high-voltage rubber gloves, face shield, insulated boots, protective raincoat or apron).
 - Bring the following equipment:
 - Class ABC powder-type fire extinguisher
 - A non-conductive object – about 1.5 meters (5 feet) long – used to safely push someone away from the vehicle if they accidentally come in contact with high voltage.

2. APPROACHING A DAMAGED VEHICLE

- Disable the high-voltage electrical system using as many of the following steps as possible:
 - Secure the vehicle — place the shift lever into the PARK position. Remove the ignition key. Block the wheels if necessary. Removing the ignition key or turning it to the OFF position will disconnect the high-voltage system.
 - Disconnect the negative cable from the 12-volt battery – this will also disconnect the high voltage.
 - If possible, place the high-voltage service disconnect switch (see section on Hybrid components for location) into the service position. To place in the service position, turn counterclockwise and then lift out. Reinsert the disconnect switch with the arrow aligned to the service/shipping position.

SPECIAL NOTES:

- If the vehicle is on fire, use a Class ABC powder-type extinguisher to contain and smother the flames. Or, if water is used, large amounts are required (e.g., from a fire hydrant).
- If the vehicle has any exposed cables, make sure you are wearing insulated



TRIBUTE HYBRID EMERGENCY RESPONSE GUIDE

gloves and other protective clothing. Do not touch any broken or damaged orange cables. Treat severed lines as if they contain high voltage.

- If the vehicle is submerged in water, do not touch any high-voltage components or cables while extricating the occupant(s). Do not remove the vehicle until you are sure the high-voltage battery is completely discharged. A submerged high-voltage battery may produce a fizzing or bubbling reaction. The high-voltage battery will be discharged when the fizzing or bubbling has completely stopped.

3. IF THE HIGH-VOLTAGE BATTERY CASE HAS BEEN RUPTURED

- Just like any other battery, hose the area down with large amounts of water.

4. MOVING DAMAGED VEHICLES — WRECKER DRIVERS

- Turn the vehicle ignition key to the ACCESSORY position to release the locking steering wheel.
- If possible, remove the high-voltage service disconnect switch by turning it counterclockwise and lifting out. Reinstall in the service/shipping position.
- Follow the guidelines in the Wrecker Towing Manual.
 - Front Tow: Wheel Lift with Dolly for 4WD and No Dolly for FWD
 - Rear Tow: Wheel Lift with Dolly for All (FWD or 4WD)
 - Flat bed: Front and Rear

5. SPECIAL NOTE TO SALVAGE YARDS

- If a vehicle with a high-voltage battery is to be scrapped, the high-voltage battery must be disposed of following all local, state/provincial and federal guidelines.



TRIBUTE HYBRID EMERGENCY RESPONSE GUIDE

NOTES: